

PAINEL HOME LUMINI

V-6 31/08/23

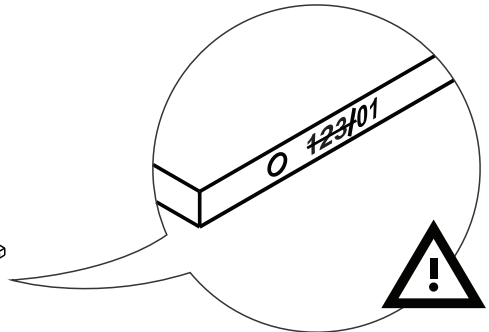
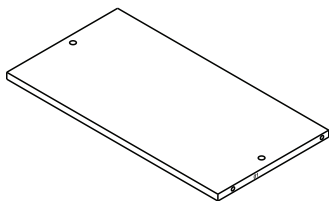
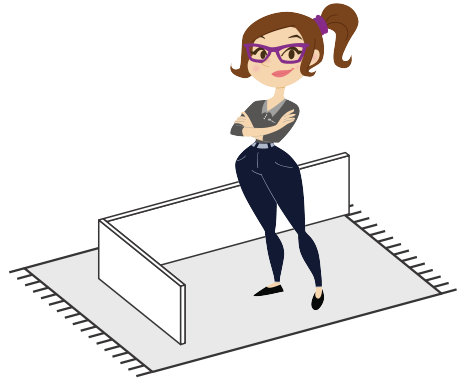
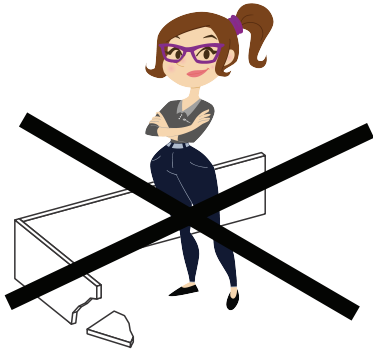
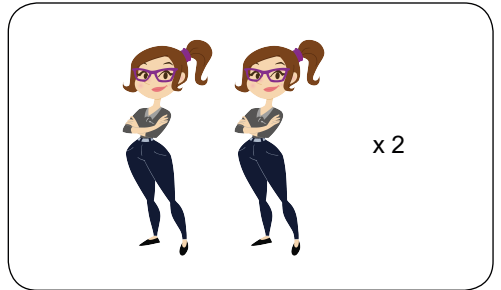
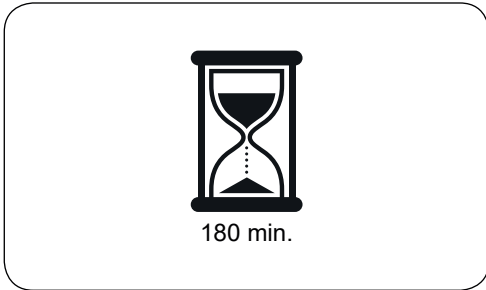
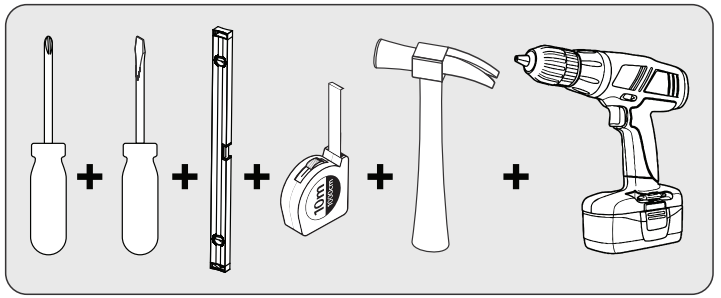
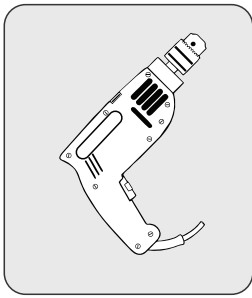

GARANTIA / GARANTIA / WARRANTY

Nossos produtos são garantidos por 90 dias contra defeitos de fabricação. Ao constatar um problema coberto pela garantia, entre em contato com a loja onde o produto foi comprado. Ela estará capacitada para atendê-lo da melhor forma diante de cada caso. Reclamações de garantia somente poderão ser atendidas se o termo de garantia for apresentado no ato de reivindicação, acompanhado de sua nota fiscal de compra.

Nuestros productos están garantidos contra defectos de fabricación por 90 días, a partir de la compra. Ao constatar un problema protegido por la garantía, póngase en contacto con la tienda donde se adquirió el producto. Ella estará capacitada para atenderlo de la mejor manera de acuerdo con cada caso.

Our products are guaranteed against manufacturing defects for 90 days from the date of purchase. When you find a problem covered by the warranty, please contact the store where the product was purchased. The store is able to serve you in the best way in each case.

Exclusões

- Desgaste natural ou danos causados por água, maresia, ferrugem, incêndio, calor, cupins e pragas em geral.
- Montagem, manutenção e uso inadequado.
- Não cumprimento das recomendações técnicas do esquema.
- Montagens e desmontagens após a primeira instalação.
- Instalações elétricas e outras afins.

Exclusiones

- Desgaste natural o daños causados por agua, maresia, incendios, calor, termitas y plagas en general.
- Montaje, mantenimiento y uso inadecuado.
- No cumplimiento de las recomendaciones técnicas del esquema.
- Montaje y desmontaje después de la primera instalación.
- Instalaciones eléctricas y otras afines.

Exclusions

- Natural wear or damage caused by water, sea, rust, fire, heat, termites and plagues in general.
- Assembly, maintenance and improper use.
- Failure to comply with the technical recommendations of the assembly instructions.
- Assembly and disassembly after first installation.

Importante

A Linea Brasil não autoriza nenhuma pessoa, loja ou entidade assumir em seu nome qualquer outra garantia que não conste no certificado. A fabricante reserva-se no direito de efetuar nos produtos eventuais modificações que considerar necessárias, sem prejudicar as características essenciais. Os produtos terão peças de assistência para reposição no período de 1 ano a contar de sua retirada do mercado, desde que haja matéria-prima equivalente, observando o dispositivo no Art.32 da Lei 8.078/90 (Cód. Defesa do Consumidor). O atendimento para produtos fora de linha é feito por programação especial, através da loja revendedora sob aprovação de consulta prévia ao fabricante.

Importante

Linea Brasil no autoriza a ninguna persona, tienda o entidad a asumir en su nombre cualquier otra garantía que no figure en el certificado. El fabricante se reserva el derecho de efectuar en los productos eventuales modificaciones que considere necesarias, sin perjudicar las características esenciales. Los productos tendrán piezas de asistencia para reposición en el período de 1 año a partir de su retirada del mercado. La atención para productos fuera de línea es hecha por programación especial, a través de la tienda revendedora bajo aprobación de consulta previa al fabricante.

Important

Linea Brasil does not authorize any person, store or entity to assume on its behalf any other warranty that does not appear on the certificate. The manufacturer reserves the right to make in the products any modifications that it considers necessary without prejudice to the essential characteristics. The products will have replacement parts within one year of being withdrawn from the market. The service for off-line products is done by special programming, through the store reseller under prior consultation with the manufacture.

INSTRUÇÕES DE LIMPEZA E CONSERVAÇÃO

INSTRUCCIONES PARA LA LIMPIEZA E CONSERVACION / CLEAN AND PRESERVATION INSTRUCTURE

Para retirar o pó, utilize um pano seco, espanador ou aspirador. Se necessário, para uma limpeza mais efetiva, utilize um pano levemente umedecido com água. Finalize com uma flanela limpa e seca.

Para eliminar el polvo, utilice un paño seco, mopa o la aspiradora. Si es necesario, para una limpieza más eficaz, utilice un paño ligeramente humedecido con agua. Terminar con un paño limpio y seco.

To take dirty, use a dry cloth, duster or vacuum. If necessary to take the dust, use a wet cloth. Finish with a clean and dry flannel.

IMPORTANTE / IMPORTANTE / IMPORTANT



Não utilize produtos abrasivos como álcool e detergentes, como também esponjas rígidas ou palha de aço na limpeza dos móveis.
No use limpiadores abrasivos como alcohol y detergentes, así como esponjas rígidas o lana de acero para limpiar los muebles.
Do not use abrasives such as alcohol and detergent, tough soaker also steel wool to clean the furniture.



Proteja a superfície do móvel de objetos que transmitam calor ou umidade.
Proteja la superficie del mueble de objetos que transmitan calor o humedad.
Protect the surface of the furniture against objects that can pass heat and humidity.



Evitar o contato de água e produto de limpeza com o rodapé do produto, pois poderá danificá-lo.
Evitar el contacto con agua y producto de limpieza con el rodapé del producto, pues podrá dañarlo.
Avoid the contact of water and cleaning products with baseboard, cause it should damage your product.



Procure sempre utilizar flanela limpa e seca para a limpeza.
Busque siempre utilizar flanela limpia y seca para la limpieza.
Try always to use a clean and dry flannel to cleaning.



Cuidado com objetos pontiagudos, eles podem arranhar a superfície das portas e tampo.
Cuidado con objetos afilados, ellos pueden rayar la superficie de las puertas e la tapa.
Take care with sharp objects, they can scratch the door/lid surface.

INSTRUÇÃO DE INSTALAÇÃO DE TELEVISORES

INSTRUCCIÓN DE INSTALACIÓN DE TELEVISIÓN / TELEVISION INSTALLATION INSTRUCTION

Para o uso do maior televisor indicado recomendamos a instalação da TV no painel do produto.
Para utilizar el televisor más grande indicado, recomendamos la instalación del televisor en el panel del producto.
To use the largest television indicated, we recommend installing the TV on the product panel.

TAMANHO DE TV SUGERIDO
TAMANO DE TELEVISOR SUGERIDO
SUGGESTED TV SIZE

65"

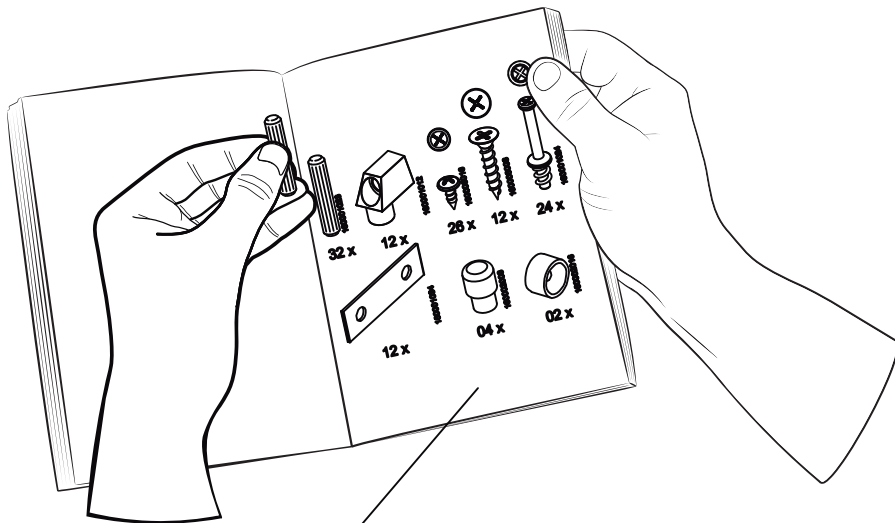

Preste Atenção! ¡Preste atención! Attention!



As ferragens dos nossos manuais são sempre apresentadas nas mesmas proporções da peça na vida real. Caso apareça alguma dúvida no decorrer do processo de montagem, coloque a ferragem ao lado do desenho e faça a consulta :D

Los accesorios de nuestros manuales siempre se presentan en las mismas proporciones que la pieza en la vida real. Si tiene alguna duda durante el proceso de montaje, coloque los accesorios junto al dibujo y haga una consulta :D

The accessories in our manuals are always presented in the same proportions as the spare part in real life. If you have any questions during the assembly process, place the accessory next to the drawing and make an inquiry :D

Símbolos: Simbolos: Symbols:



- + Parafuso Phillips
- Parafuso Fenda
- ⊙ Parafuso Allen

- + Tornillo Phillips
- Tornillo Ranurado
- ⊙ Tornillo Allen

- + Phillips screw
- Slotted Screw
- ⊙ Allenscrew

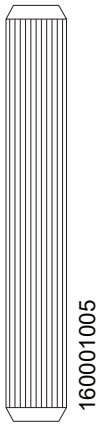

160001005

06 x

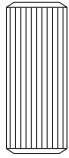

160001003

11 x

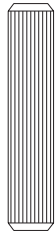

160001023

17 x

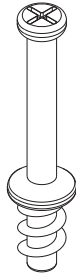

160001024

12 x

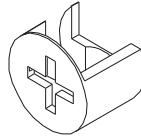

160001025

12 x



160001009

13 x

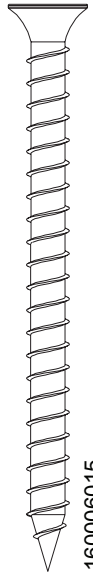

160006015

13 x

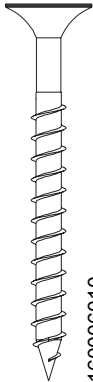

160006010

07 x



160006006

28 x

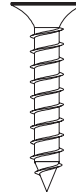

160006008

102 x



160006016

10 x

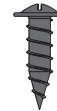

160006003

02 x

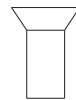

160006020

05 x



160006022

05 x

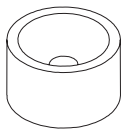

160002016

02 x

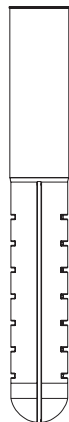

160002006

13 x



160005056

01 x

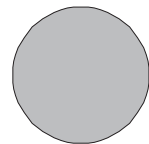

160002002

11 x

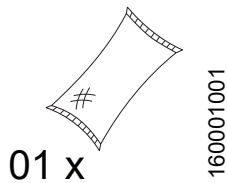
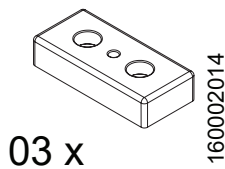
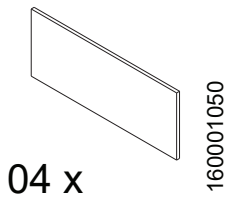
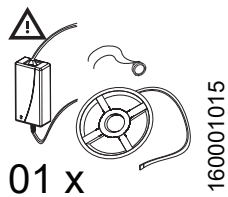
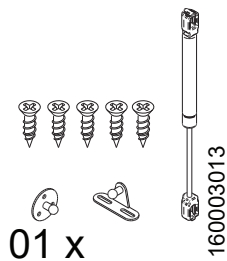
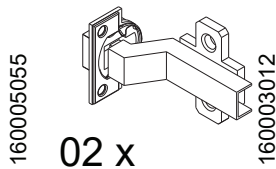
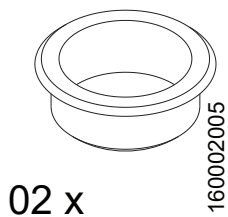

Item de compra opcional.

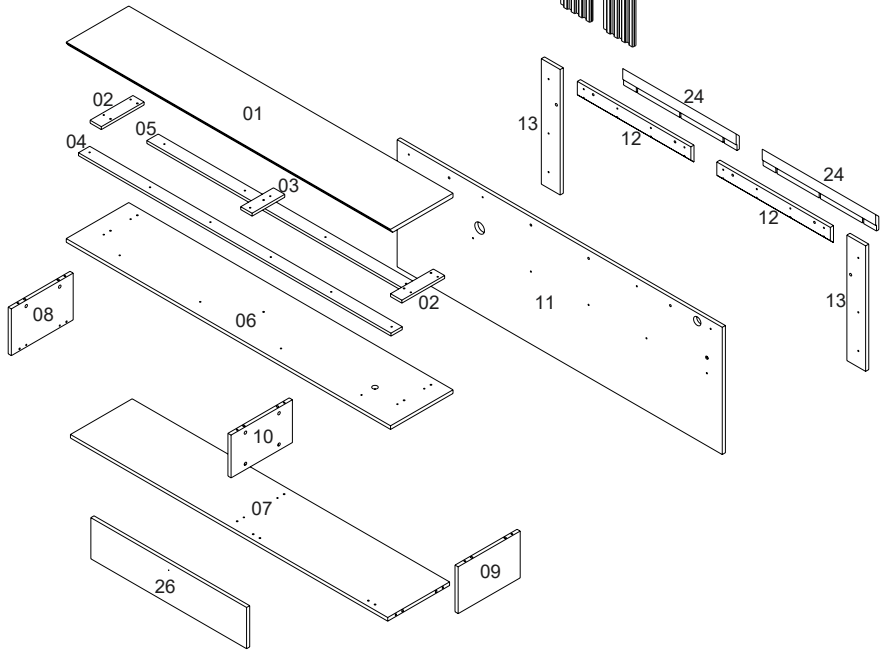
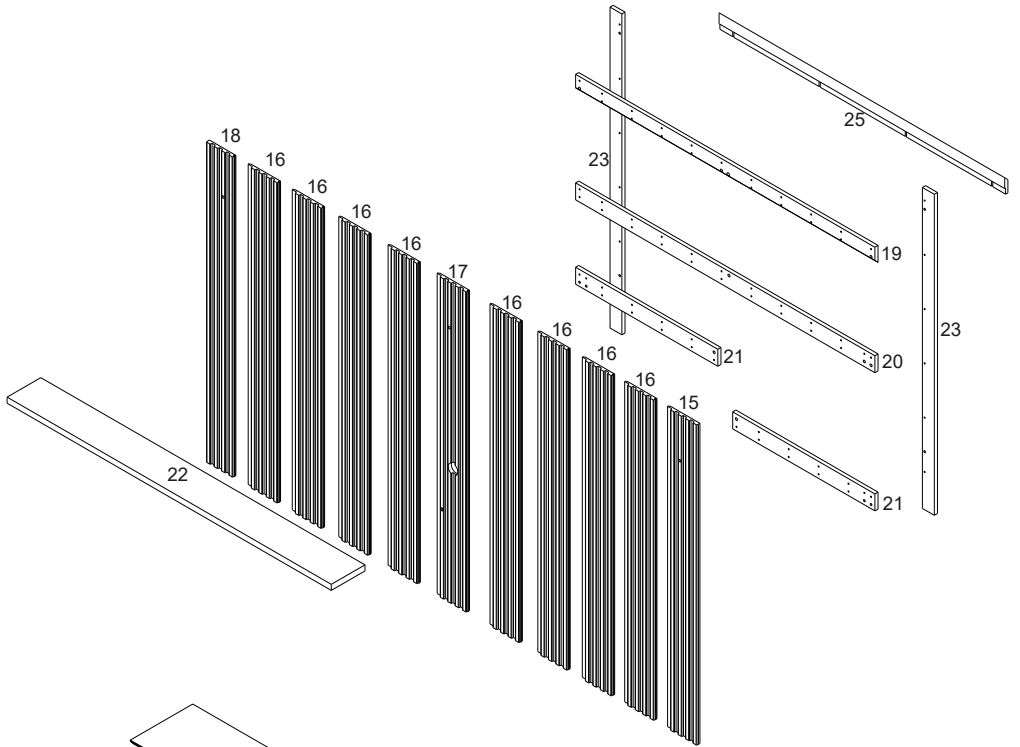

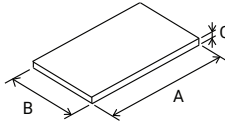

VOLUME Caja Box	ITEM Artículo Item	PEÇA Pieza Part	DESCRIÇÃO Descripción Description	DIMENSÕES (mm) Dimensión/Dimension			QUANTIDADE Cantidad Amount	MATERIAL
				A	B	C		
1	1	510229001	TAMPO SUPERIOR	1547	298	18	1	MDF
1	2	510229002	ENGROSSO LATERAL	204	64	12	2	MDP
1	3	510229003	ENGROSSO CENTRAL	156	54	12	2	MDP
1	4	510229004	ENGROSSO FRONTAL	1491	54	12	1	MDP
1	5	510229005	ENGROSSO TRASEIRO	1265	54	12	1	MDP
1	6	510229006	TAMPO INFERIOR	1547	298	15	1	MDP
1	7	510229007	BASE	1513	295	15	1	MDP
1	8	510229008	LATERAL ESQUERDA	296	193	15	1	MDP
1	9	510229009	LATERAL DIREITA	296	193	15	1	MDP
1	10	510229010	DIVISAO	293	177	15	2	MDP
1	11	510229011	PAINEL NICH0	1551	526	15	1	MDP
1	12	510229012	TRAVESSA FIXAÇÃO NICH0	541	70	15	2	MDP
1	13	510229013	TRAVESSA LATERAL NICH0	518	90	15	2	MDP
1	15	510229015	MOLDURA LATERAL DIREITA	1322	147	15	1	MDF
1	16	510229016	MOLDURA CENTRAL	1322	147	15	8	MDF
1	17	510229017	MOLDURA CENTRAL PASSA FIO	1322	147	15	1	MDF
1	18	510229018	MOLDURA LATERAL ESQUERDA	1322	126	15	1	MDF
1	19	510229019	TRAVESSA FIXAÇÃO PAINEL	1427	70	15	1	MDP
1	20	510229020	TRAVESSA CENTRAL PAINEL	1427	70	15	1	MDP
1	21	510229021	TRAVESSA INFERIOR PAINEL	678	70	15	2	MDP
1	22	510229022	PRATELEIRA SUPERIOR	1547	161	25	1	MDP
1	23	510229023	TRAVESSA LATERAL PAINEL	1325	57	15	2	MDP
1	24	510229024	TRAVESSA FIXAÇÃO PAREDE NICH0	541	70	15	2	MDP
1	25	510229025	TRAVESSA FIXAÇÃO PAREDE PAINEL	1362	70	15	1	MDP
1	26	510229026	PORTA	745	173	15	1	MDP

ARTÍCULO	DESCRIPCIÓN
1	BASE SUPERIOR
2	APOYO LATERAL
3	APOYO CENTRAL
4	APOYO FRONTAL
5	APYO DEL FONDO
6	BASE INFERIOR
7	BASE
8	LATERAL IZQUIERDA
9	LATERAL DERECHA
10	DIVISIÓN
11	PANEL DE NICH0
12	DIVISIÓN DEL FURACIÓN NICH0
13	VIGA LATERAL NICH0
15	MARCO LATERAL DERECHA
16	MARCO CENTRAL
17	MARCO CENTRAL DE GUÍA DE CABLES
18	MARCO LATERAL IZQUIERDA
19	DIVISIÓN PAINEL
20	DIVISIÓN CENTRAL PAINEL
21	DIVISIÓN INFERIOR PAINEL
22	ESTANTE SUPERIOR
23	DIVISIÓN LATERAL PAINEL
24	DIVISIÓN PARED DEL NICH0
25	DIVISIÓN PARED PAINEL
26	PUERTA

ITEM	DESCRIPTION
1	UPPER BASE
2	SIDE SUPPORT
3	CENTRAL SUPPORT
4	FRONTAL SUPPORT
5	BACK SUPPORT
6	LOWER BASE
7	BASE
8	LEFT SIDE
9	RIGHT SIDE
10	DIVISION
11	NICHE PANEL
12	NICHE FIXATION DIVISION
13	NICHE SIDE DIVISION
15	RIGHT UPPER RIGHT
16	CENTRAL FRAME
17	CABLE GUIDE CENTER FRAME
18	LEFT UPPER FRAME
19	PANEL DIVISION
20	PANEL CENTRAL DIVISION
21	PANEL LOWER DIVISION
22	UPPER SHELF
23	PANEL SIDE DIVISION
24	WALL DIVISION
25	PANEL WALL DIVISION
26	DOOR

1

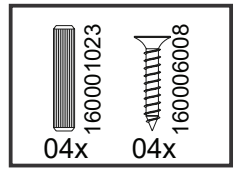
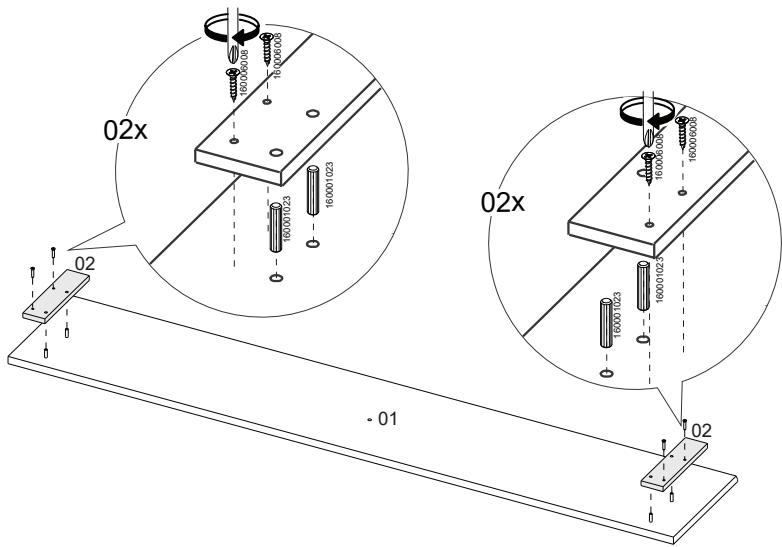

2

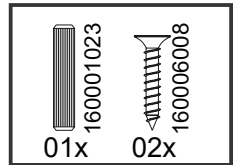
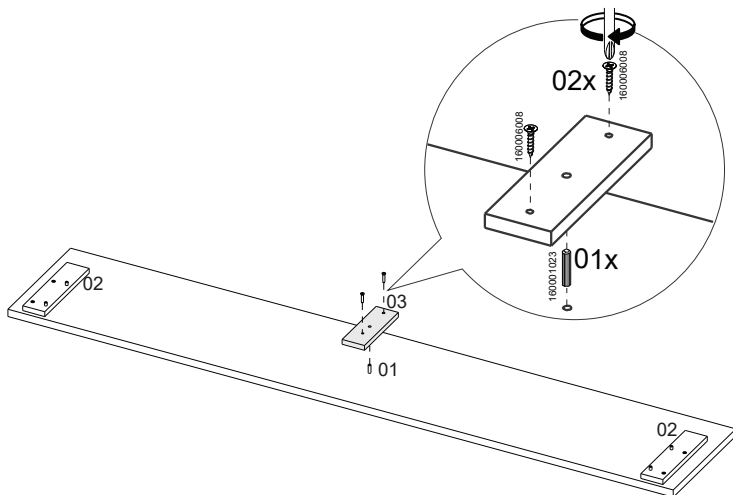

3

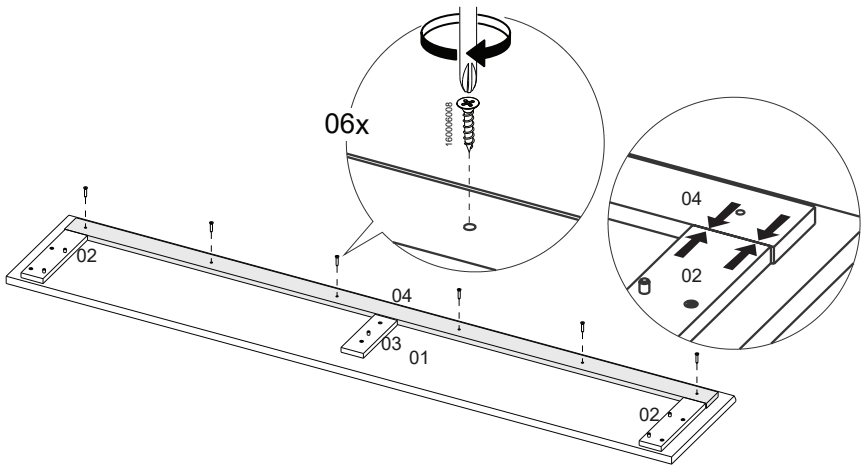
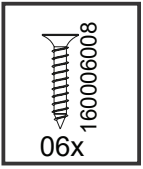

4

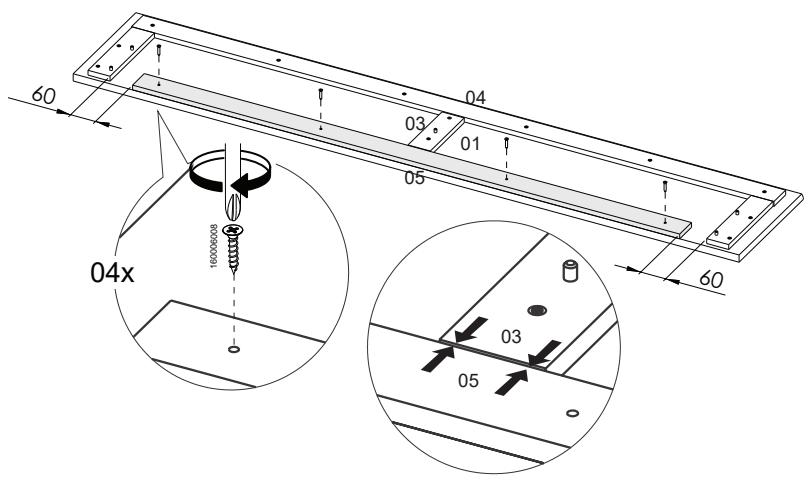
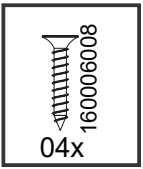

5

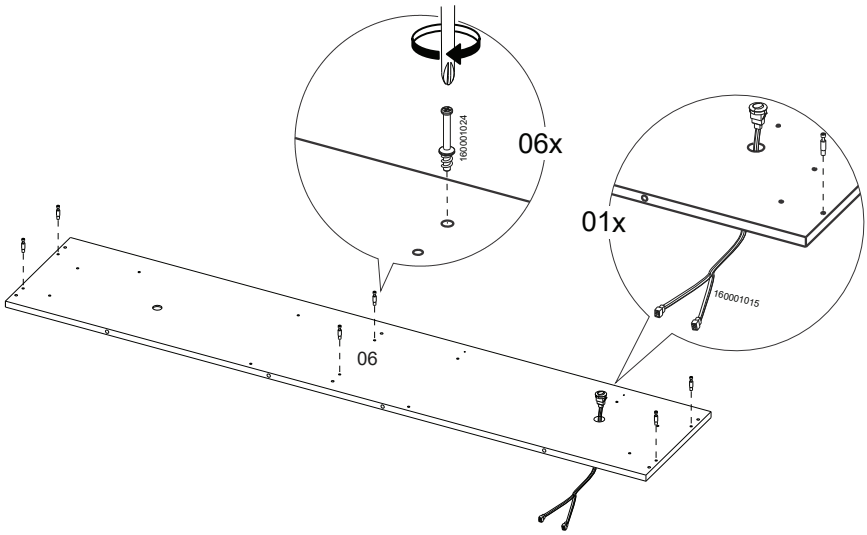
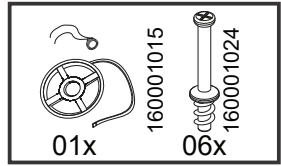

6

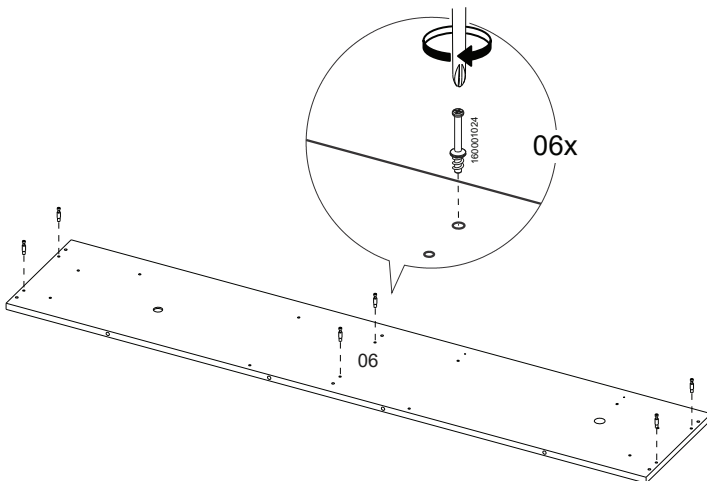
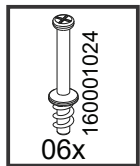

7

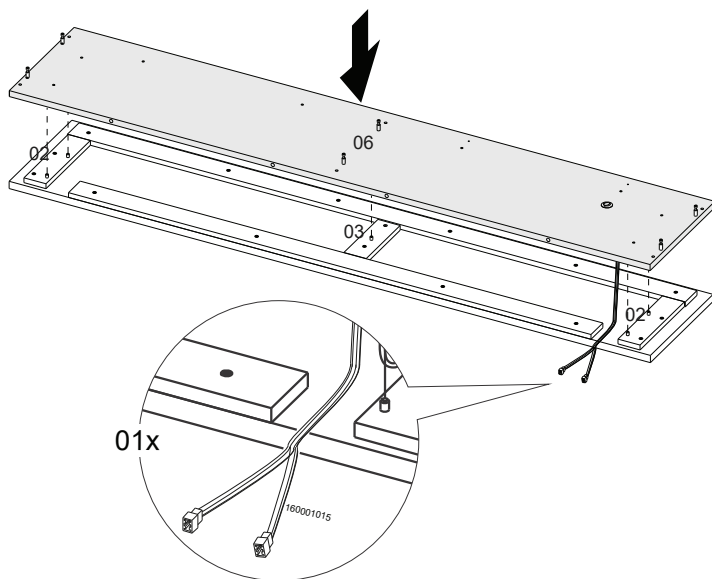

8

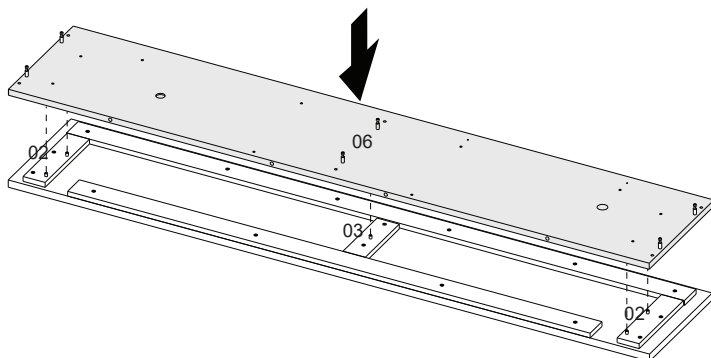

9

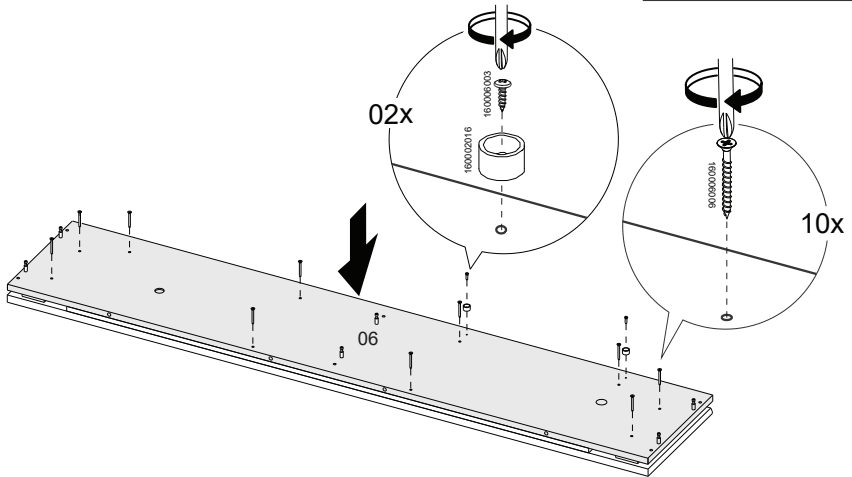
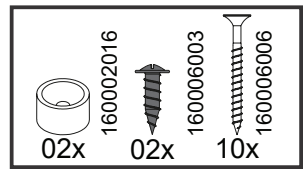

10

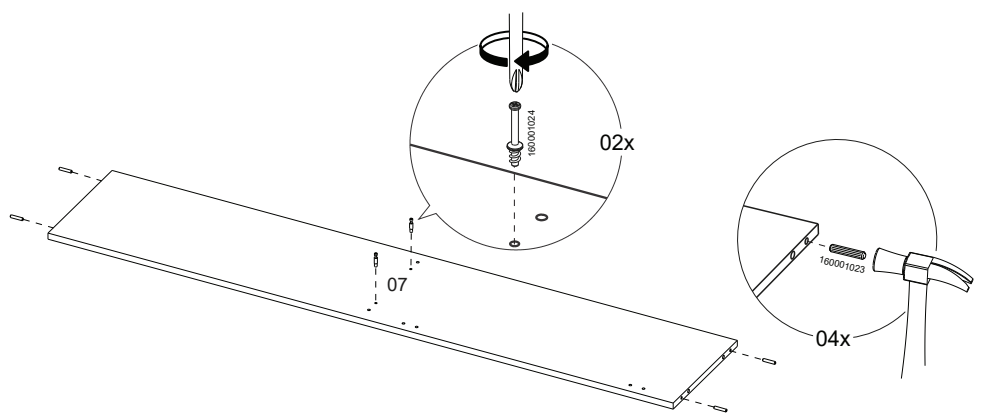
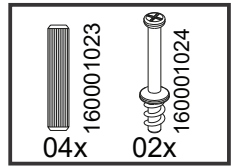

11

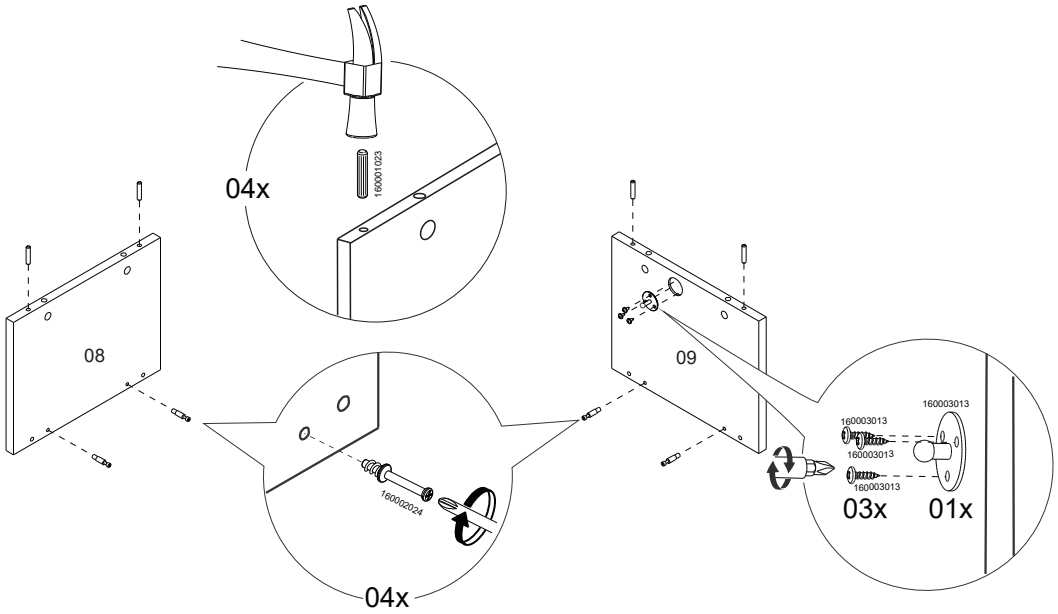
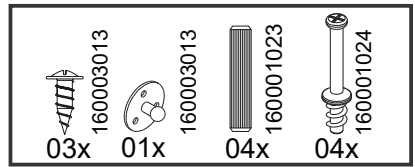

12

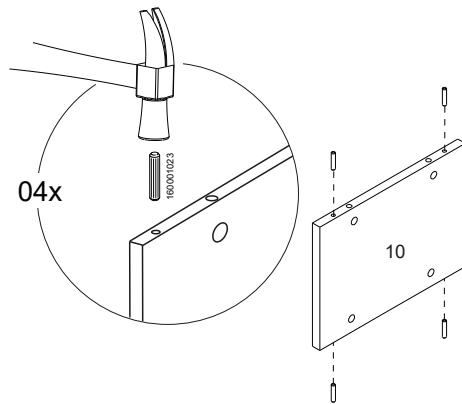
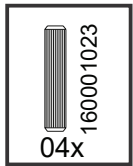

15

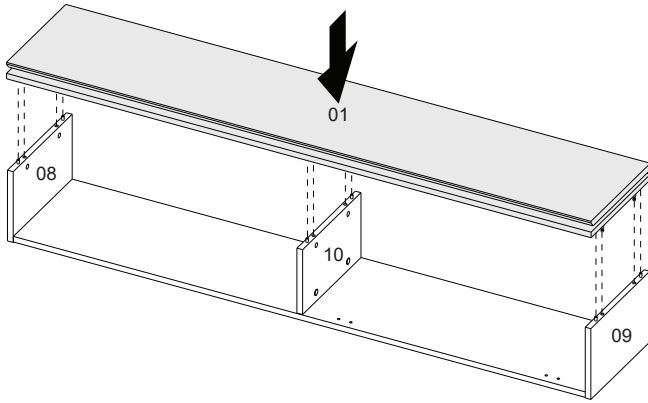

16

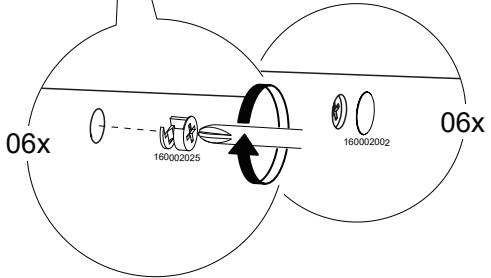
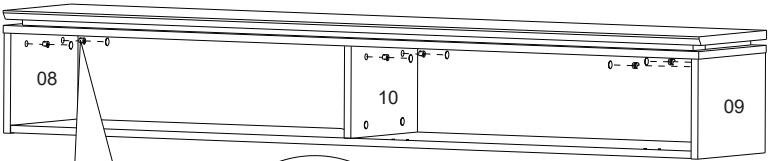
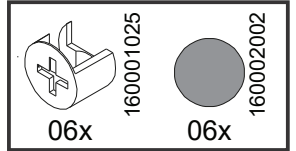
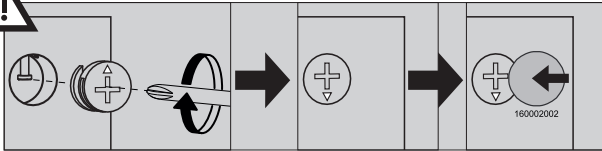

17

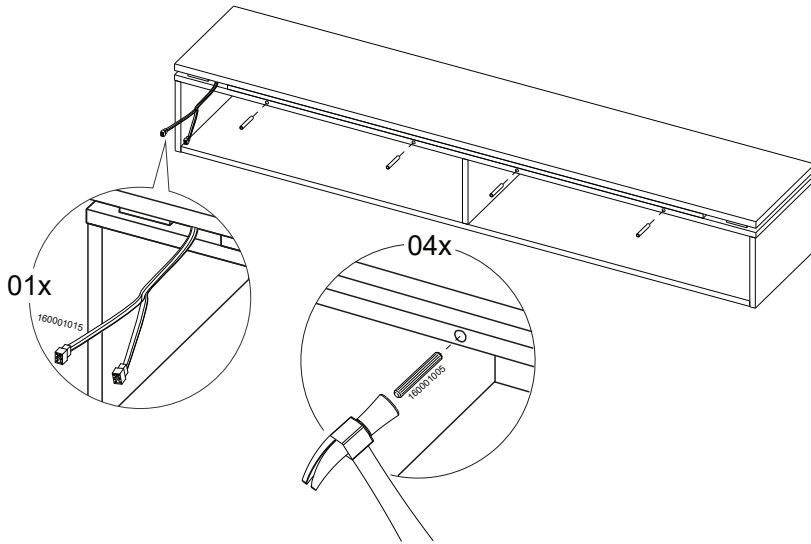
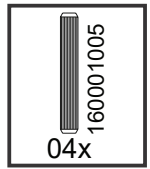

18

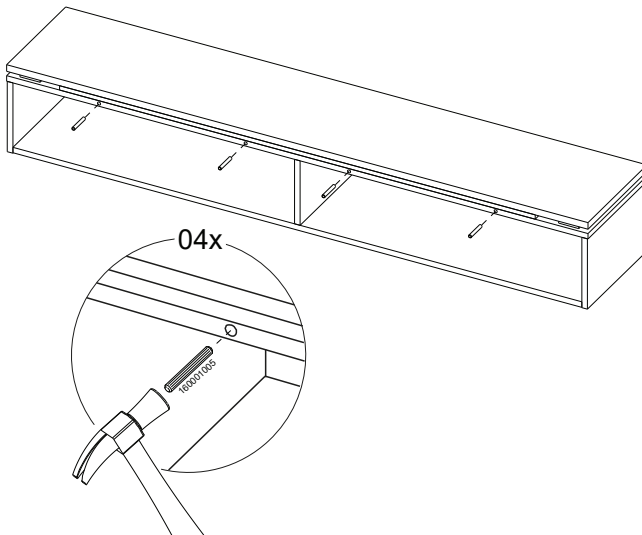
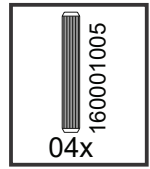

19

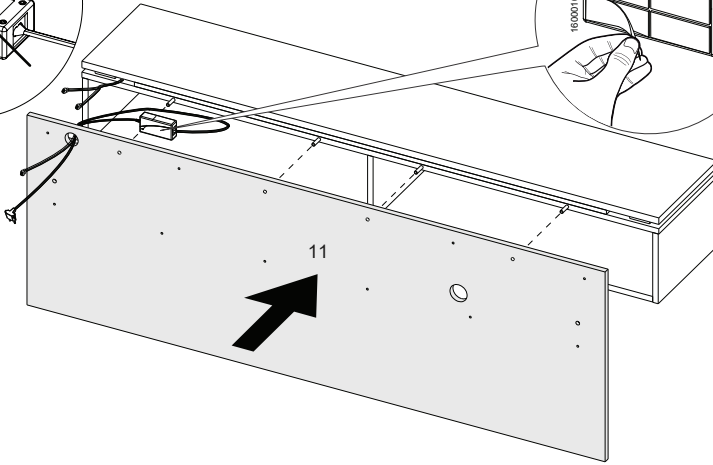
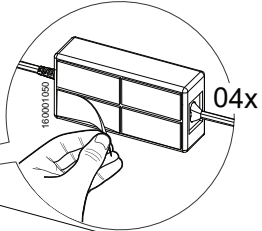
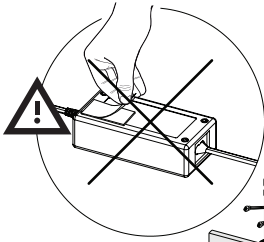
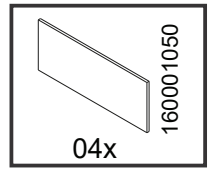

20

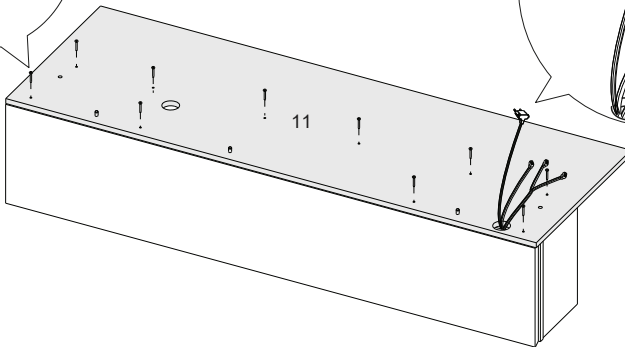
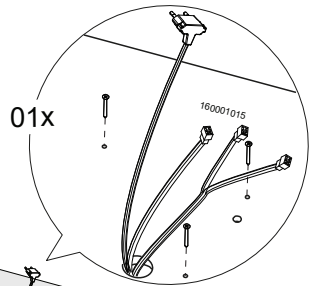
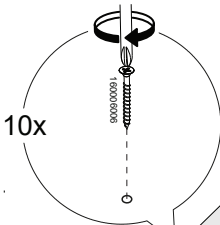
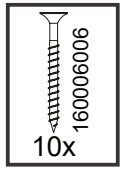

21

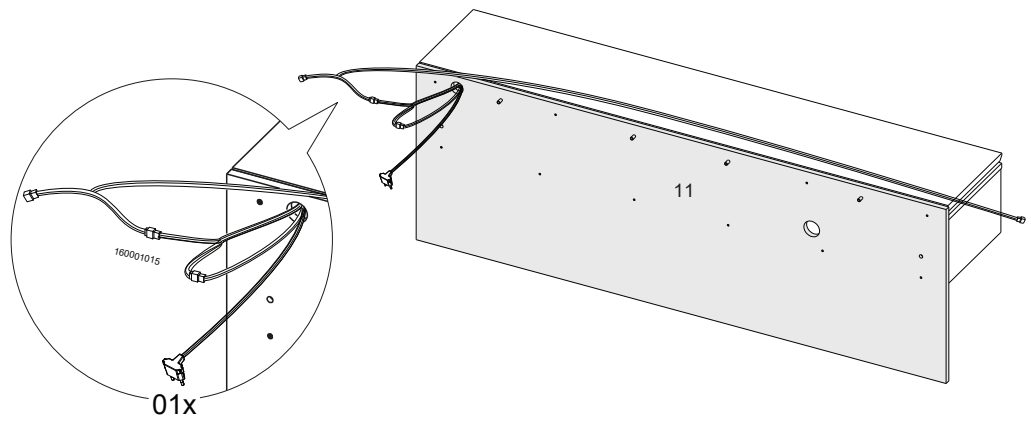

22

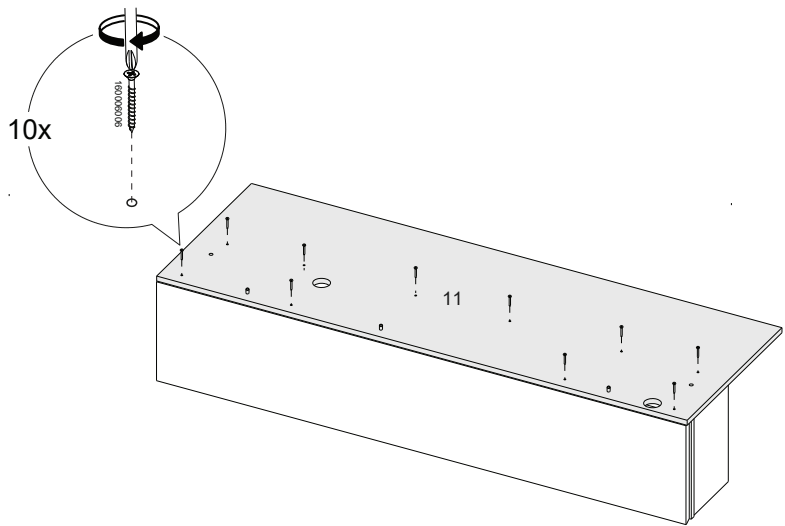
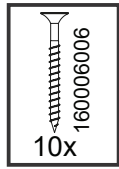

23

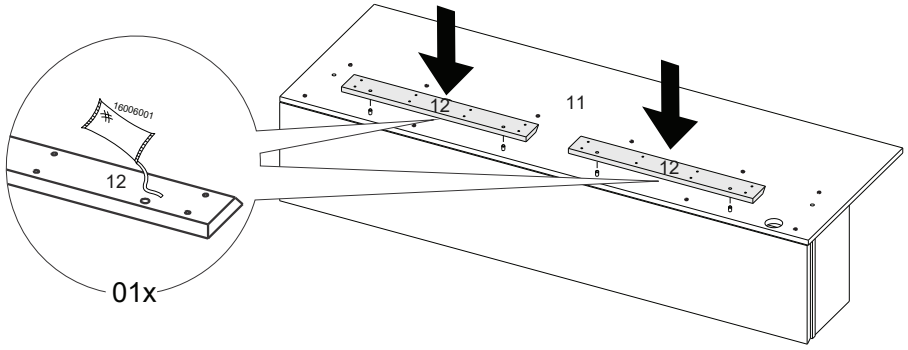
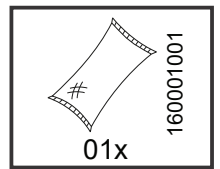

24

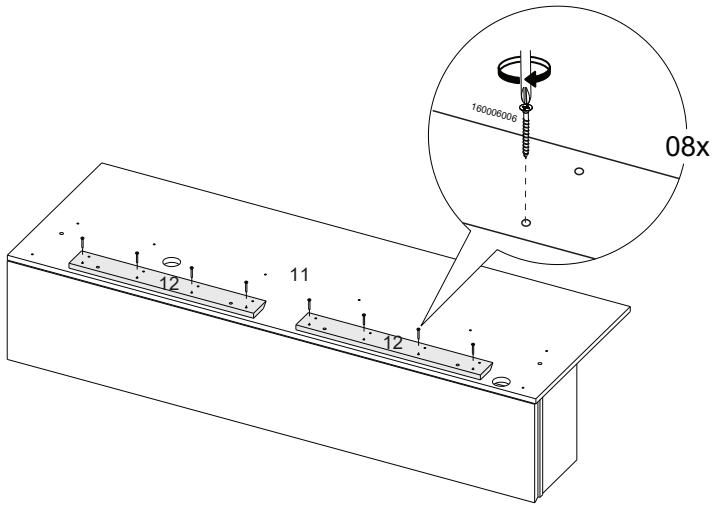
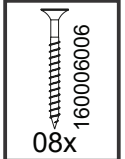

25

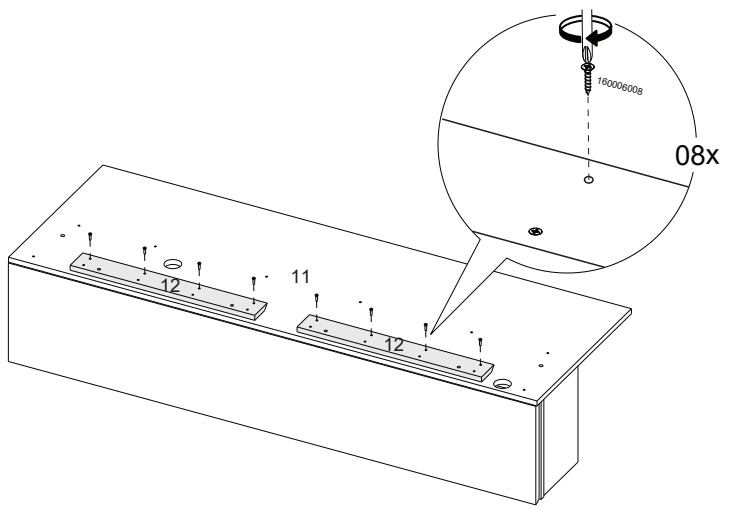
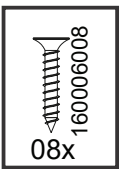

26

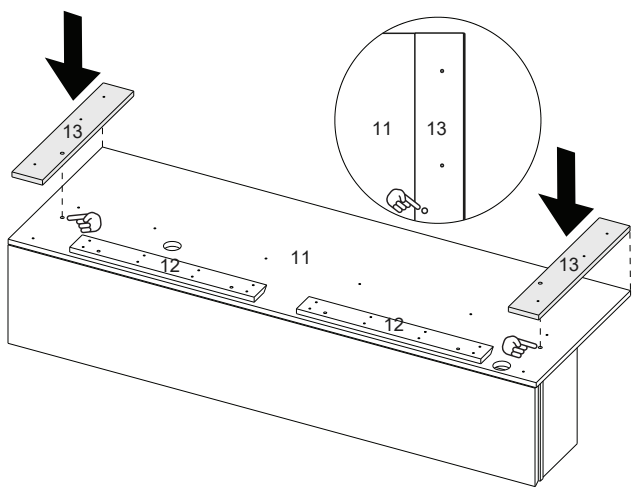

27

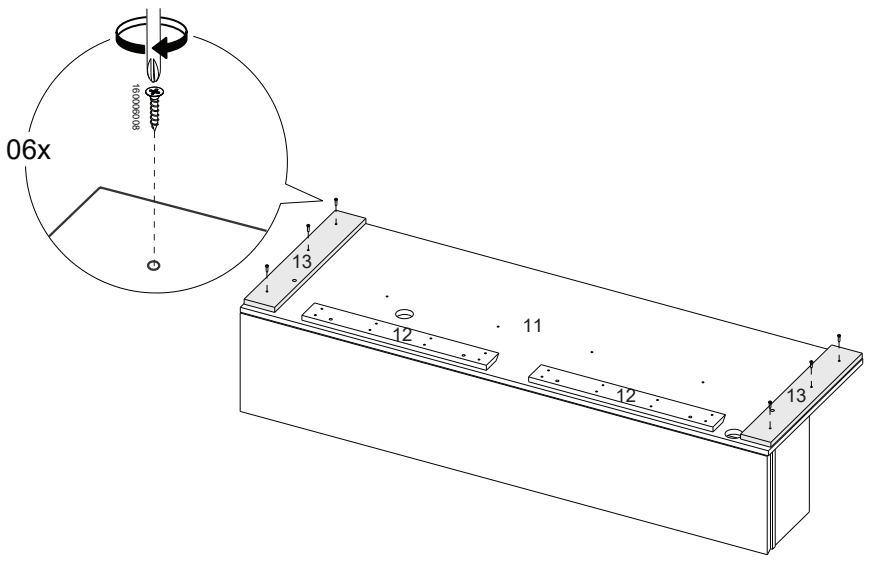
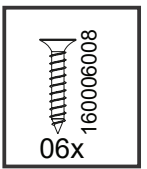

28

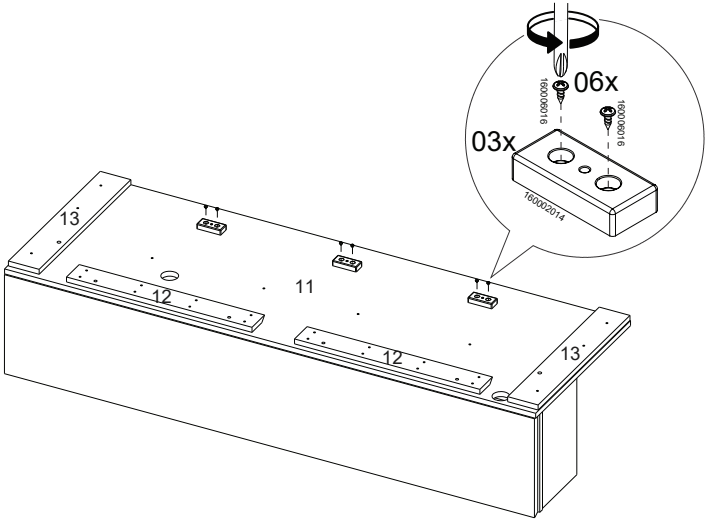
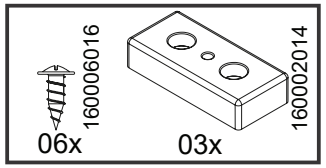

29

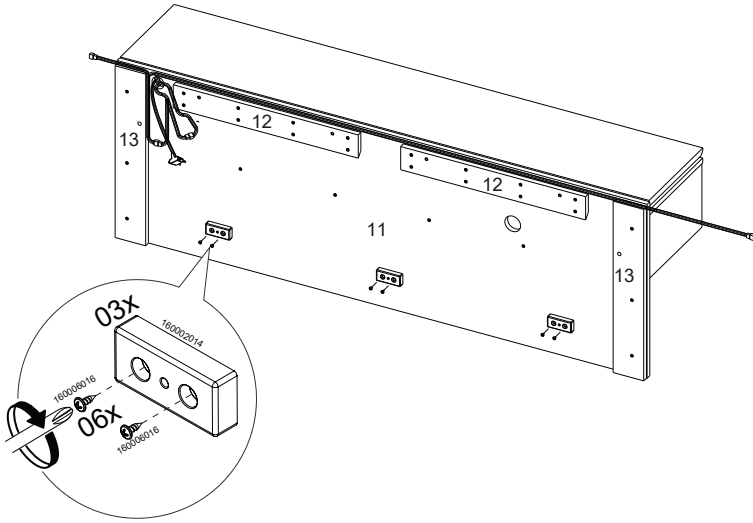
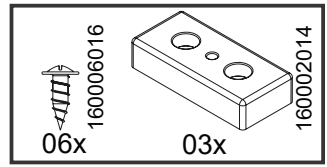

30

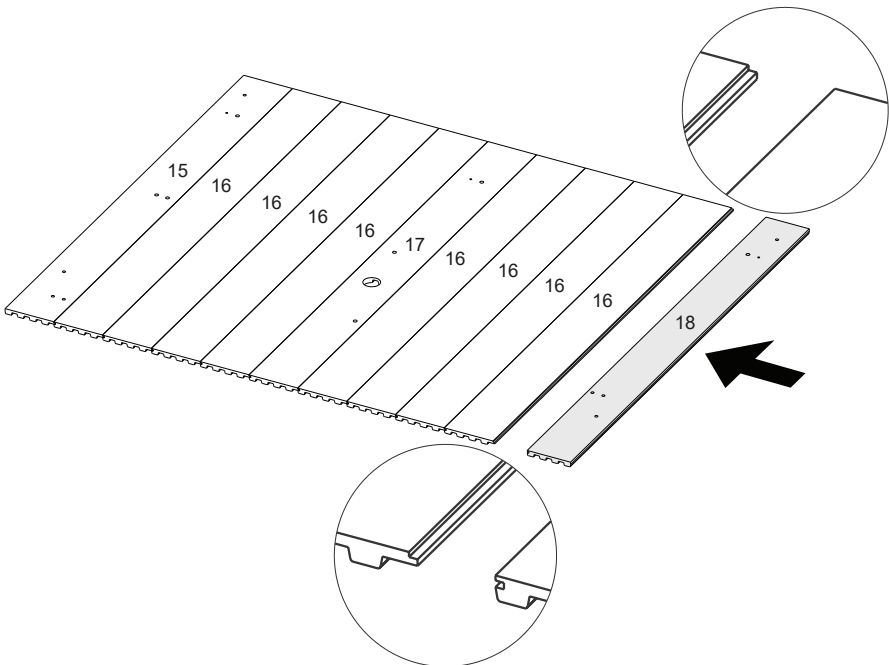

31

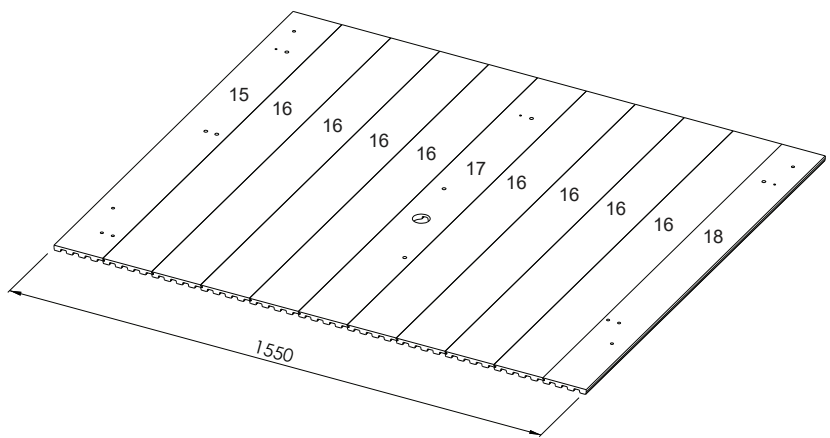
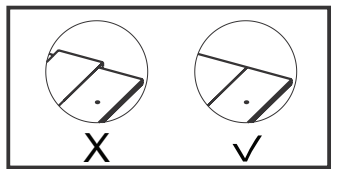

32

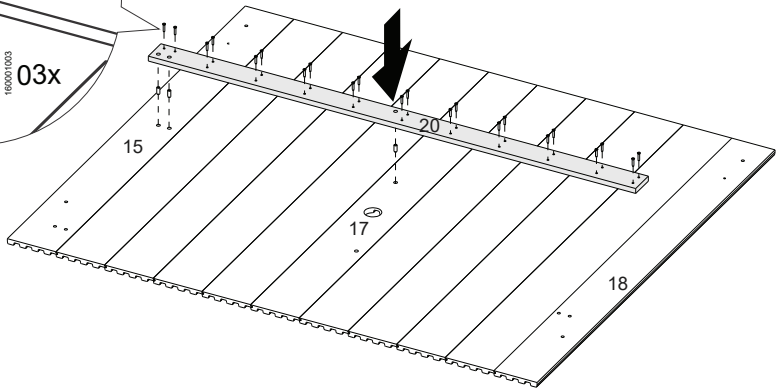
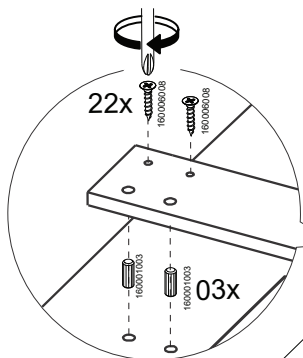
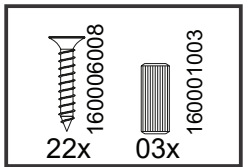

33

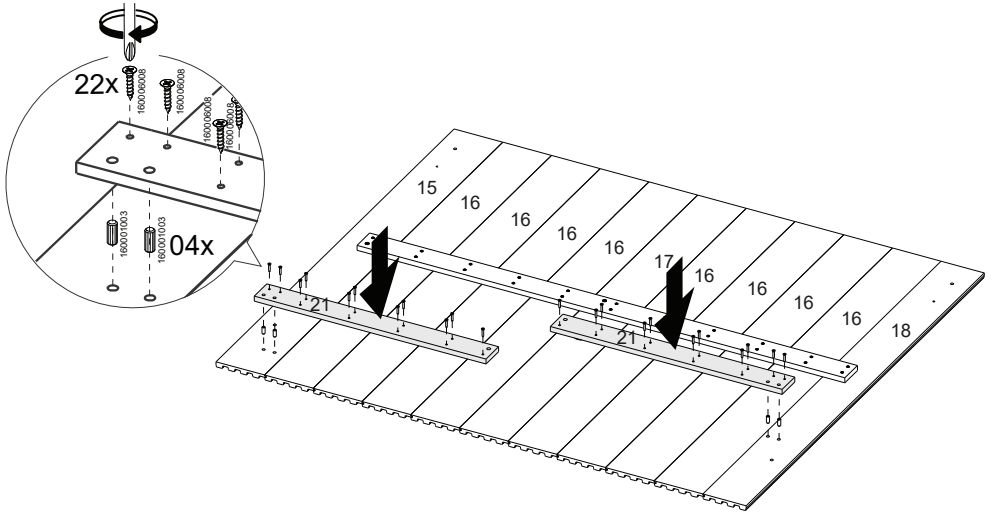
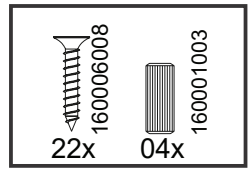

34

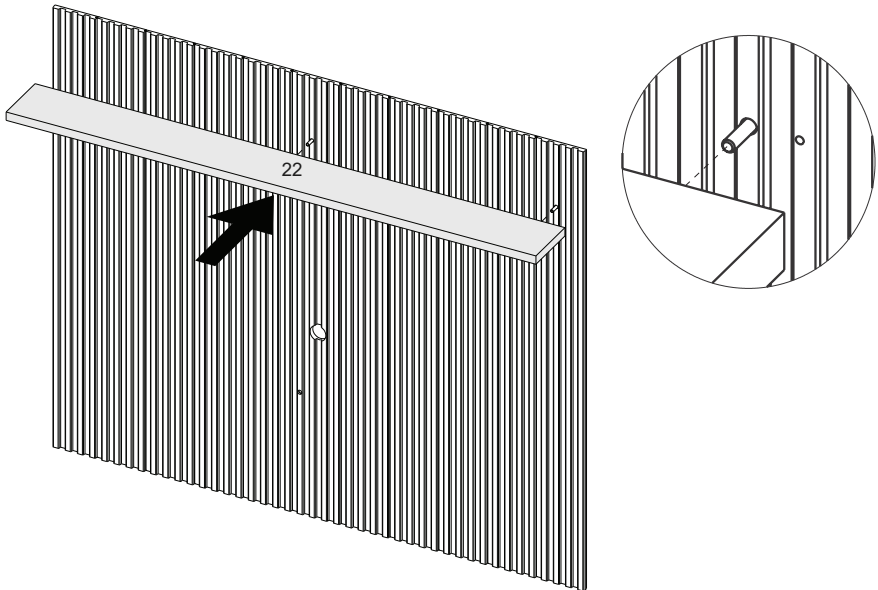

35

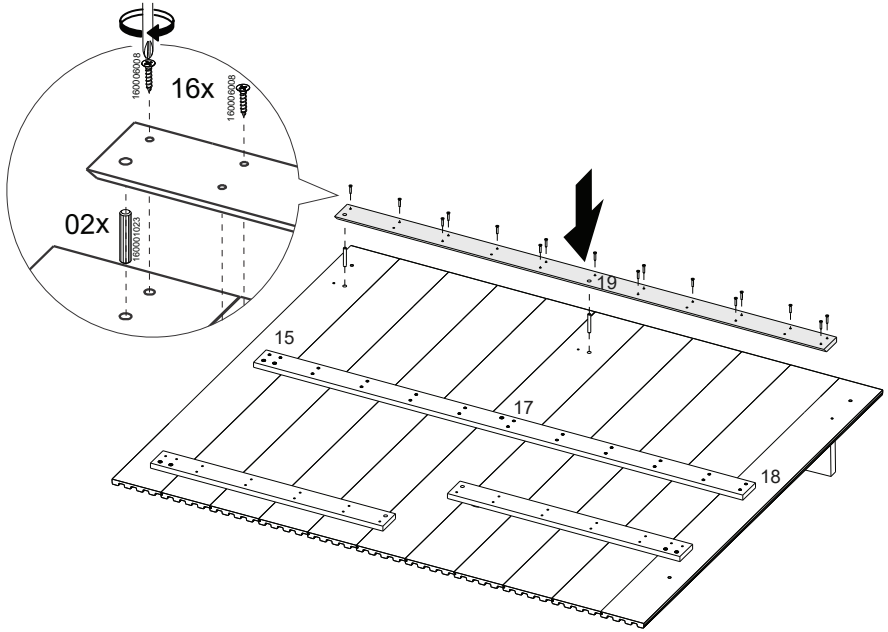
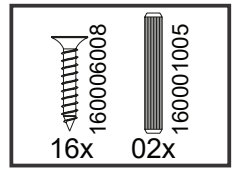

36

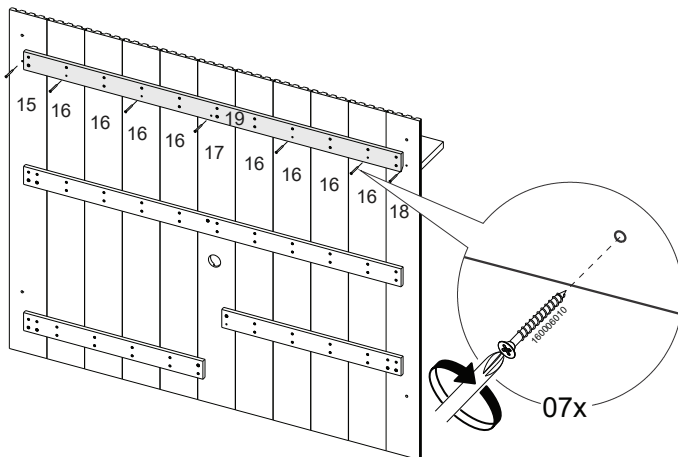
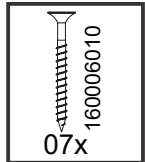

37

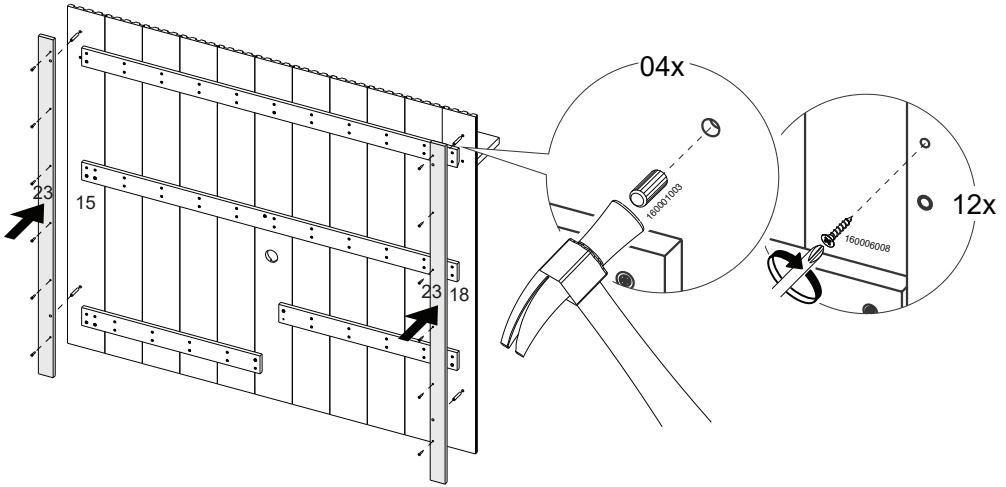
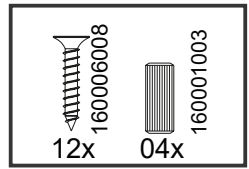

38

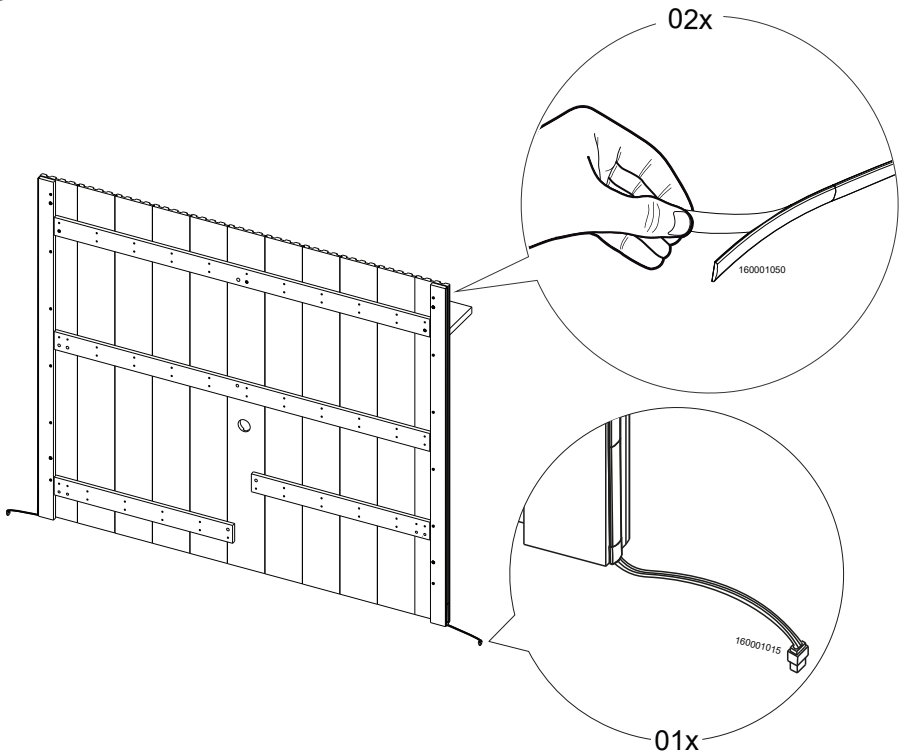

39

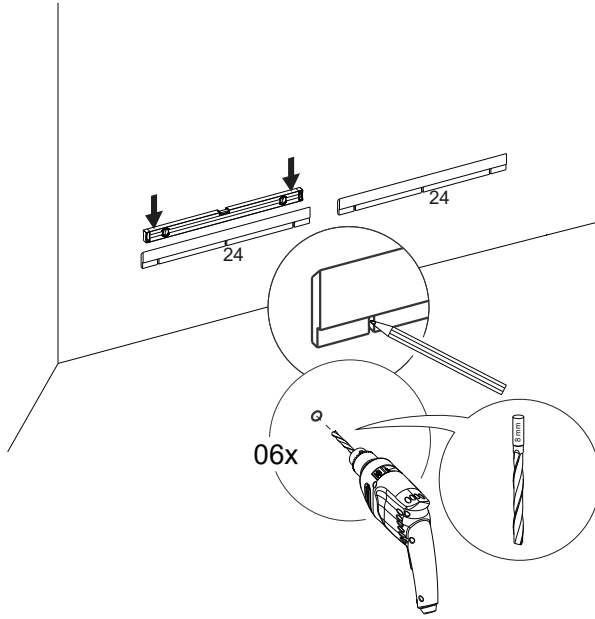

40

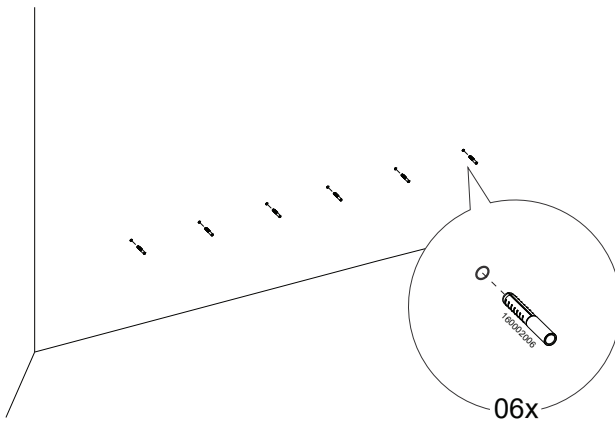
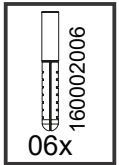

41

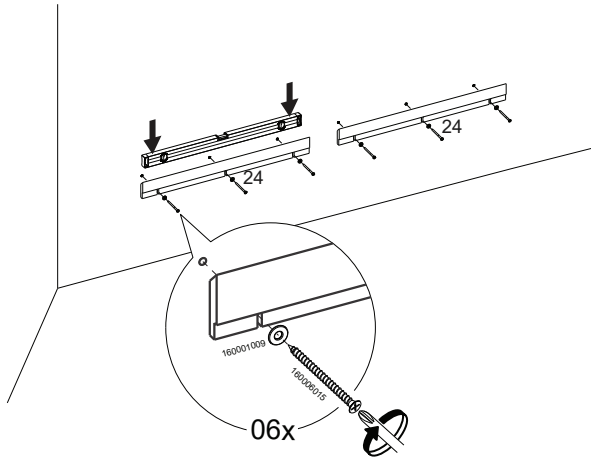
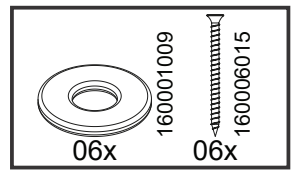

42

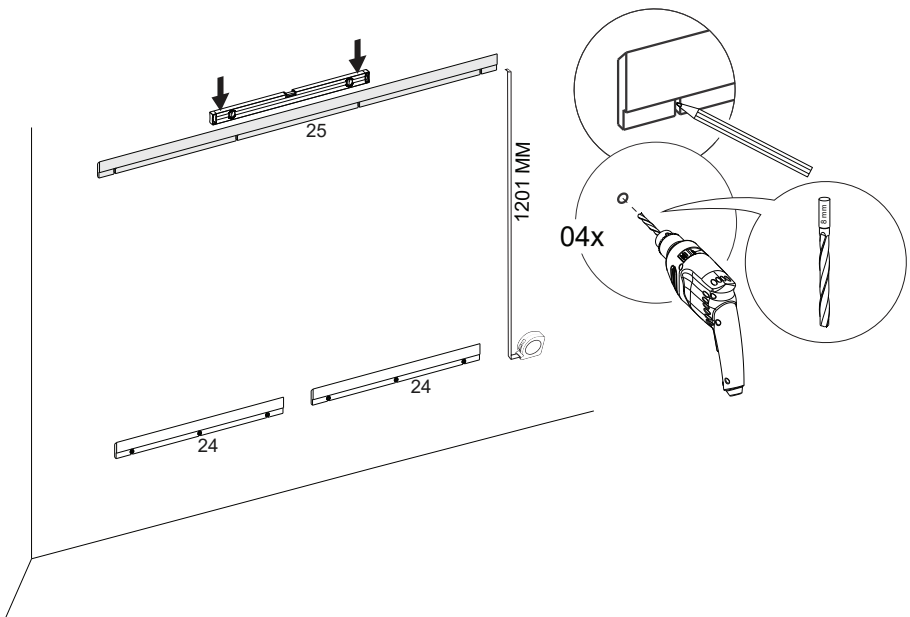

43

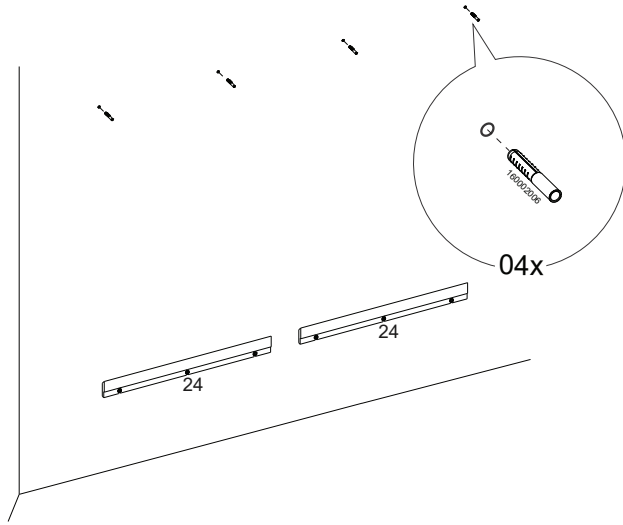
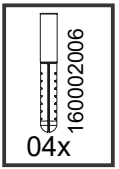

44

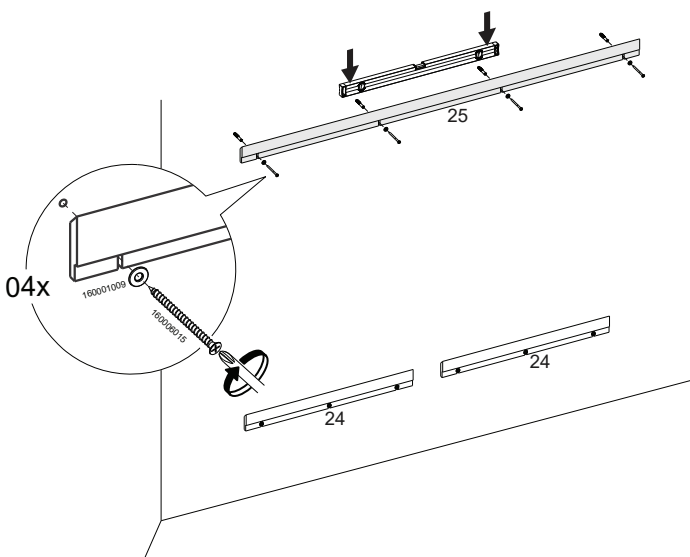
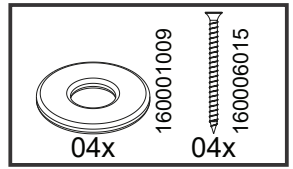

45

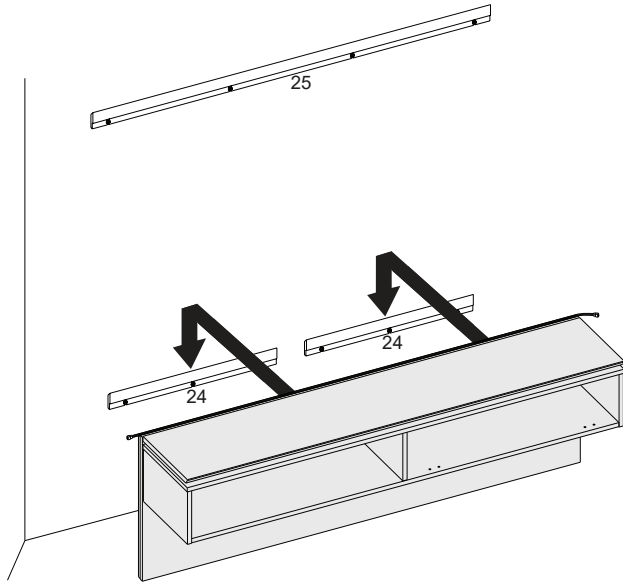

46

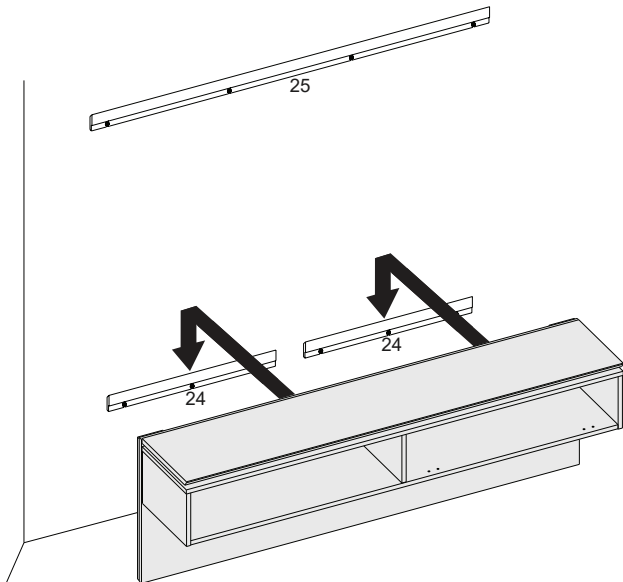

47

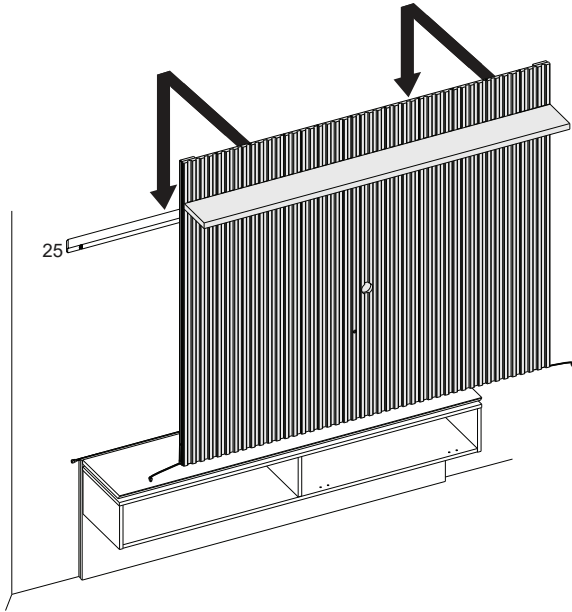

48

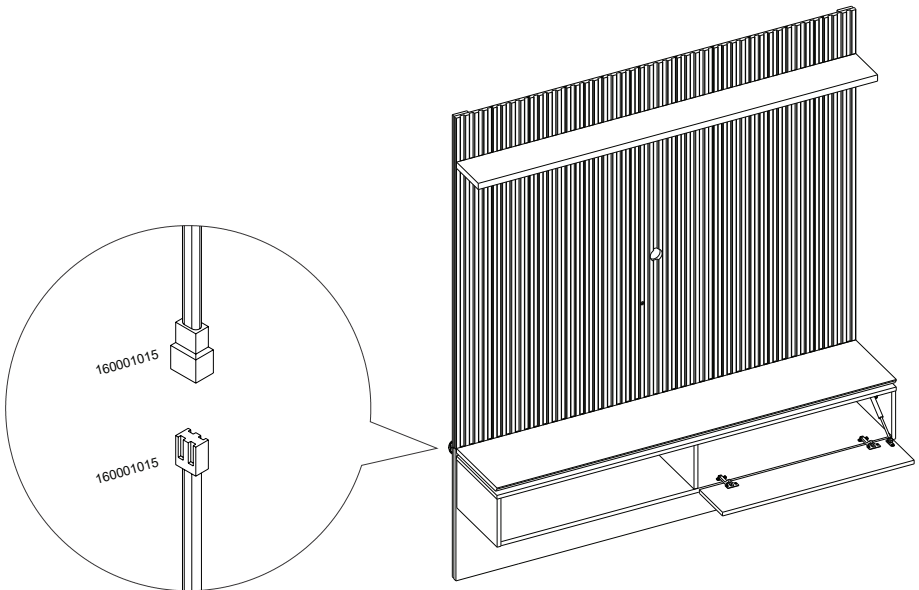

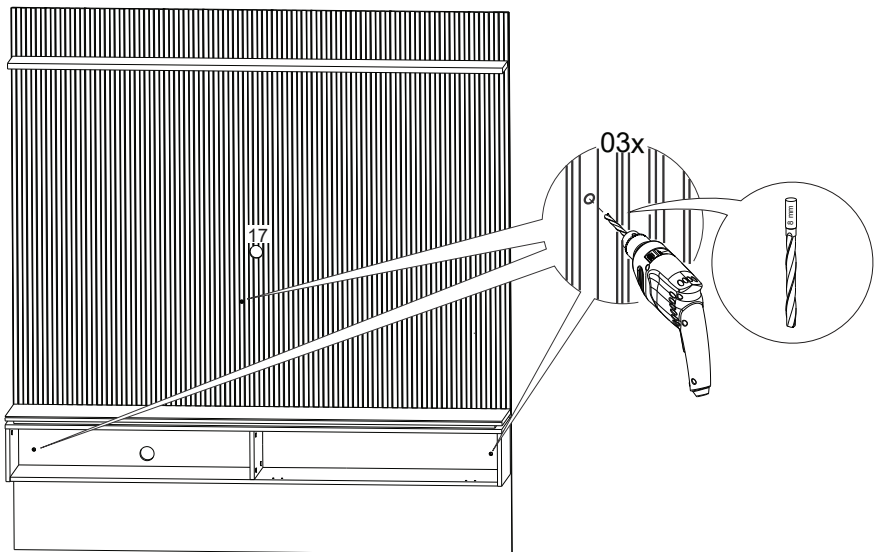
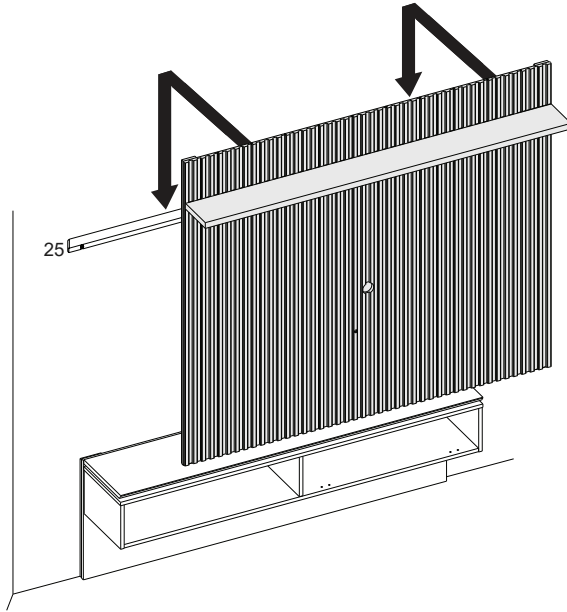

51

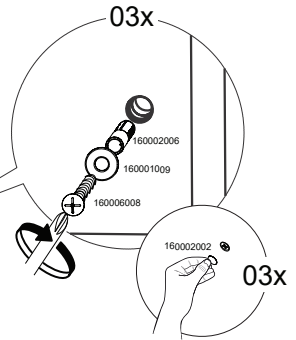
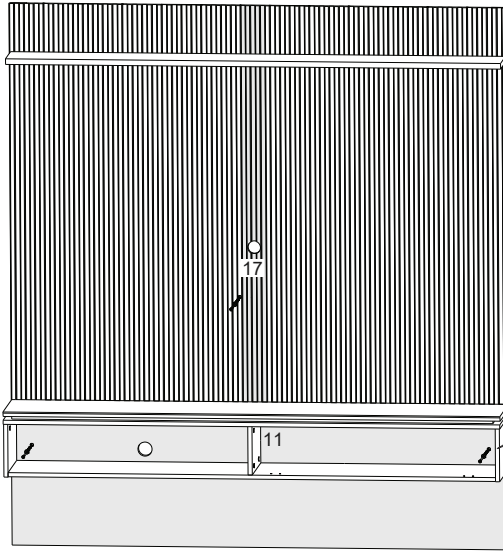
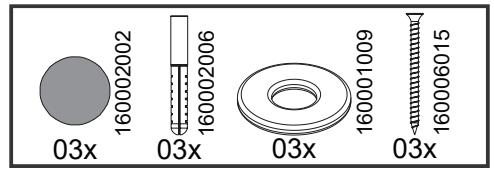

52

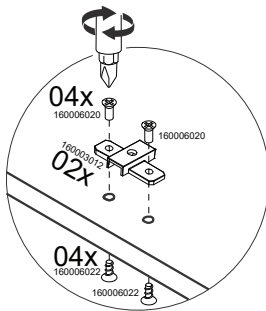
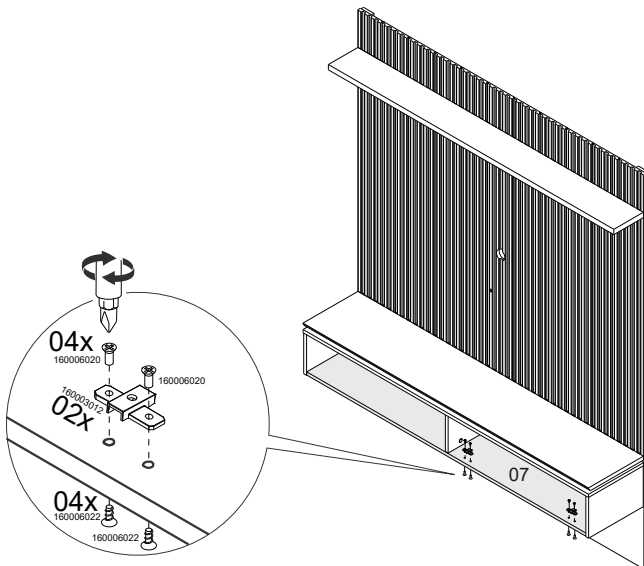
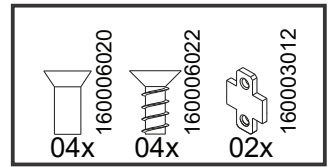

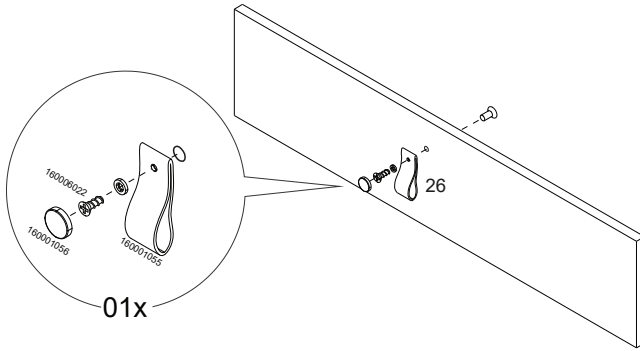
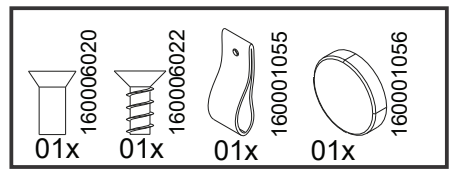

53

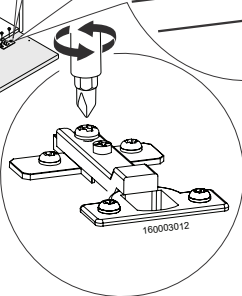
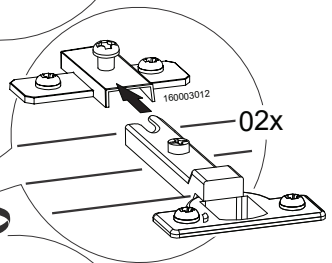
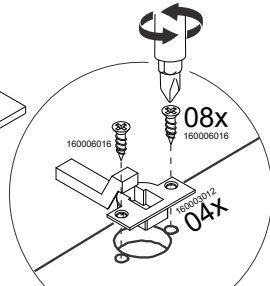
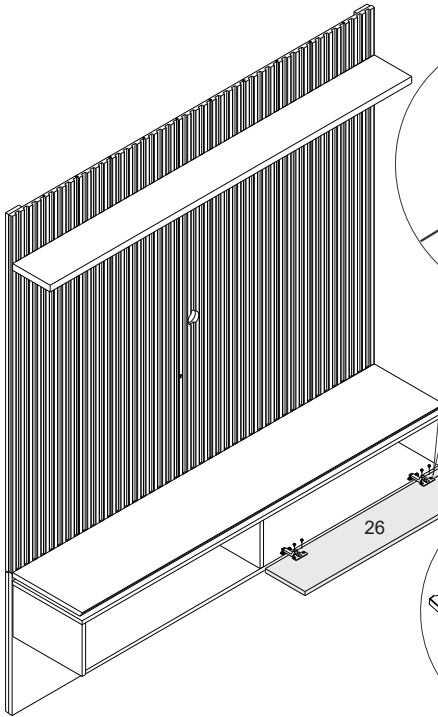
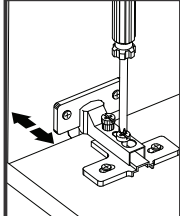
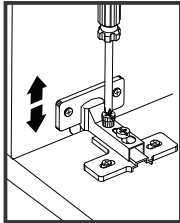
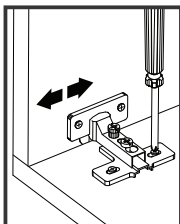
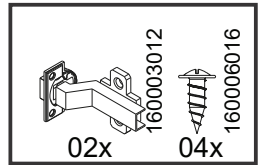

54



	160003013		160003013
02x		01x	

